



---

*Technologie für innovative  
Transport-Bestandteile  
von Swissmetro zu CargoTube*

*Marcel Jufer Hon Prof EPFL*

# Swissmetro

- Die wichtigsten Agglomerationen unseres Landes zu verbinden und Passagiere bei Geschwindigkeiten von 400 km/Std zu transportieren
- Zwei Tunnel, einen in jede Richtung, mit kleinem Durchmesser (5m), mit Teilvakuum
- Ein magnetisches Trag- und Führungssystem, ohne Materialabnutzung
- Ein Antriebssystem durch lineare Elektromotoren
- Kontaktlos Energieübertragung durch Induktion

# Schweiz

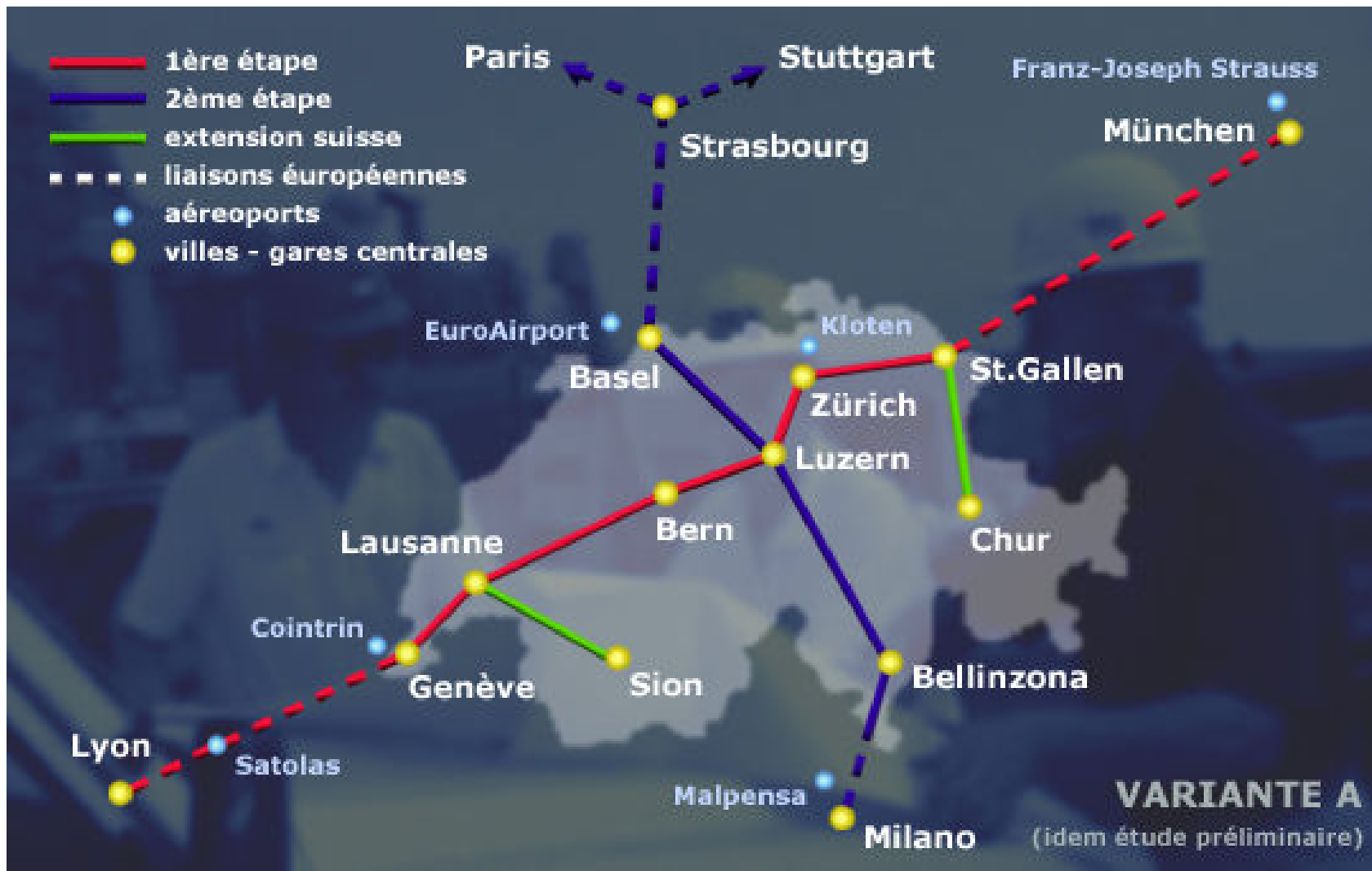



ÉCOLE POLYTECHNIQUE  
FÉDÉRALE DE LAUSANNE

numexia

# *Swissmetro*

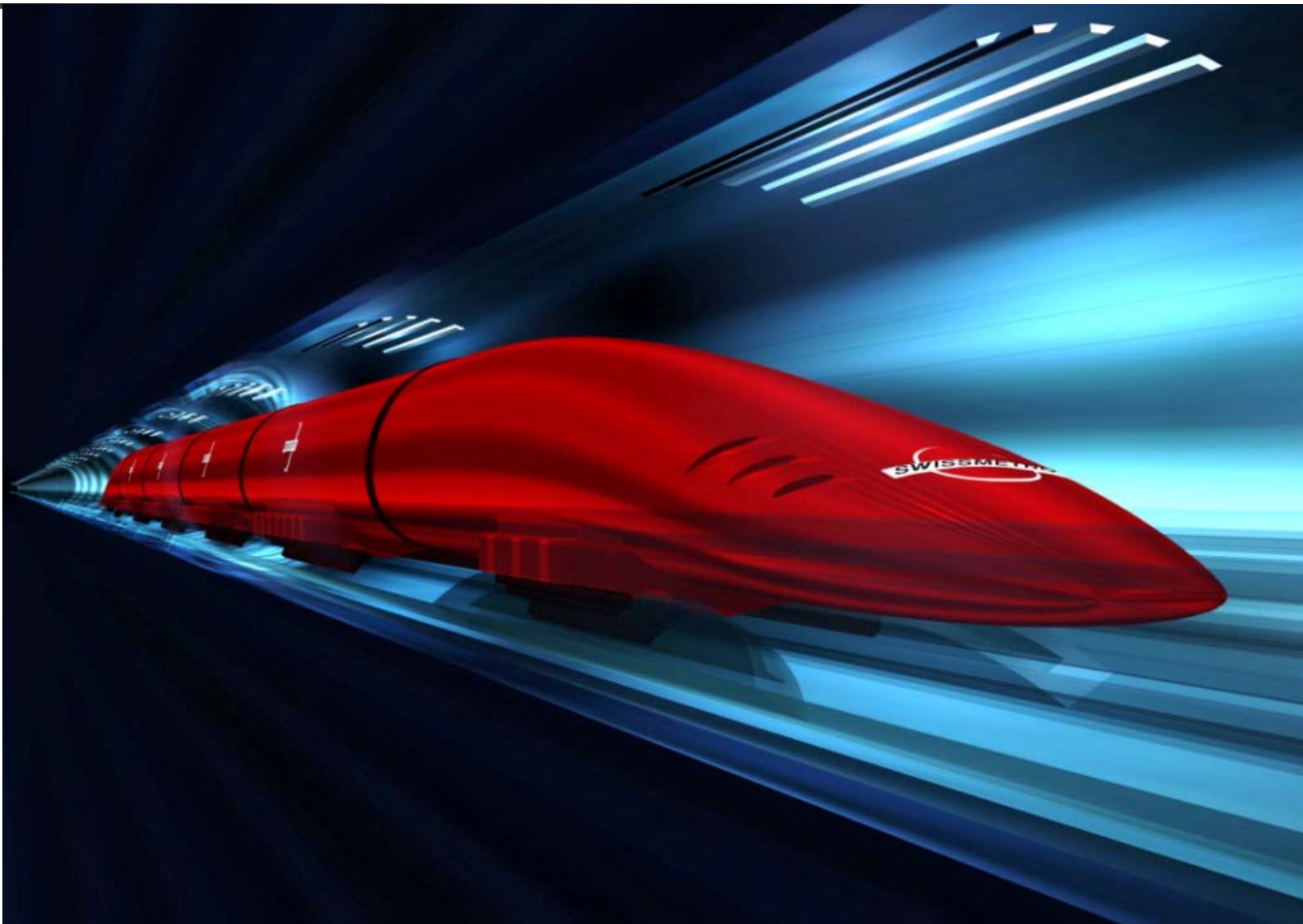

# Querschnitt

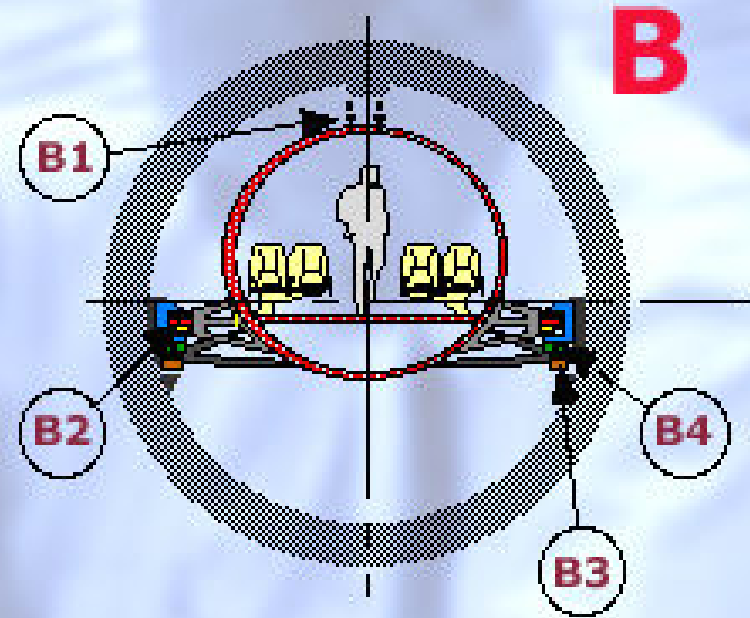
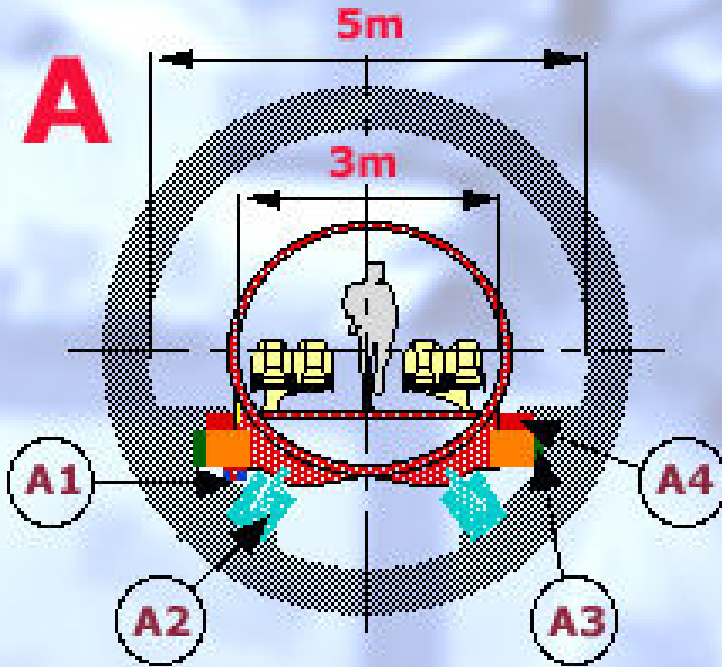

## Variante A (moteur dans le tunnel)

- A1 = Transmission d'énergie par induction
- A2 = Moteurs linéaires fixés au tunnel
- A3 = Inducteur de guidage
- A4 = Inducteur de sustentation

## Variante B (moteur embarqué)

- B1 = Transmission d'énergie par induction
- B2 = Moteurs linéaires embarqués
- B3 = Inducteur de guidage
- B4 = Inducteur de sustentation

# Querschnitt

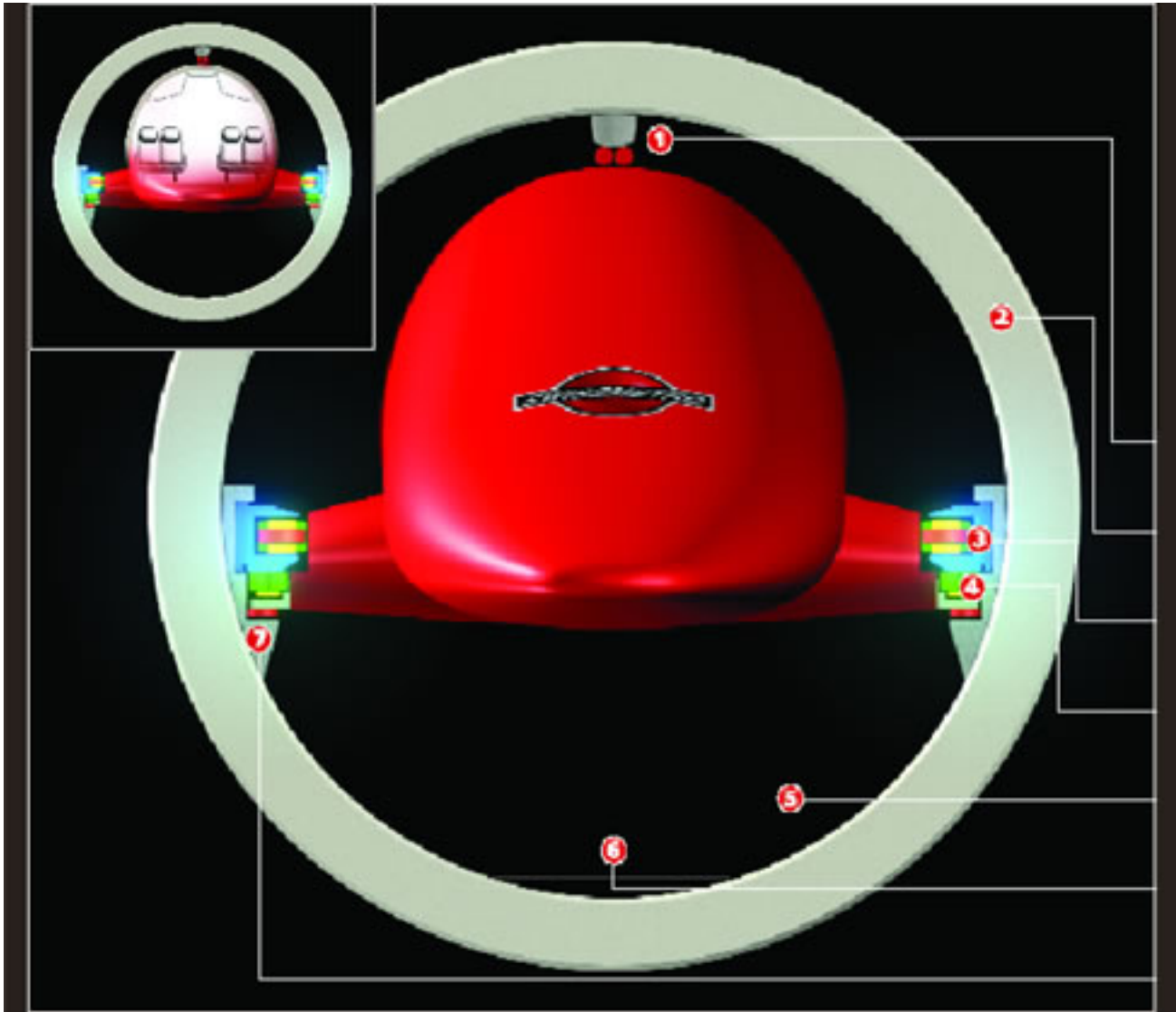

# *Revolver*

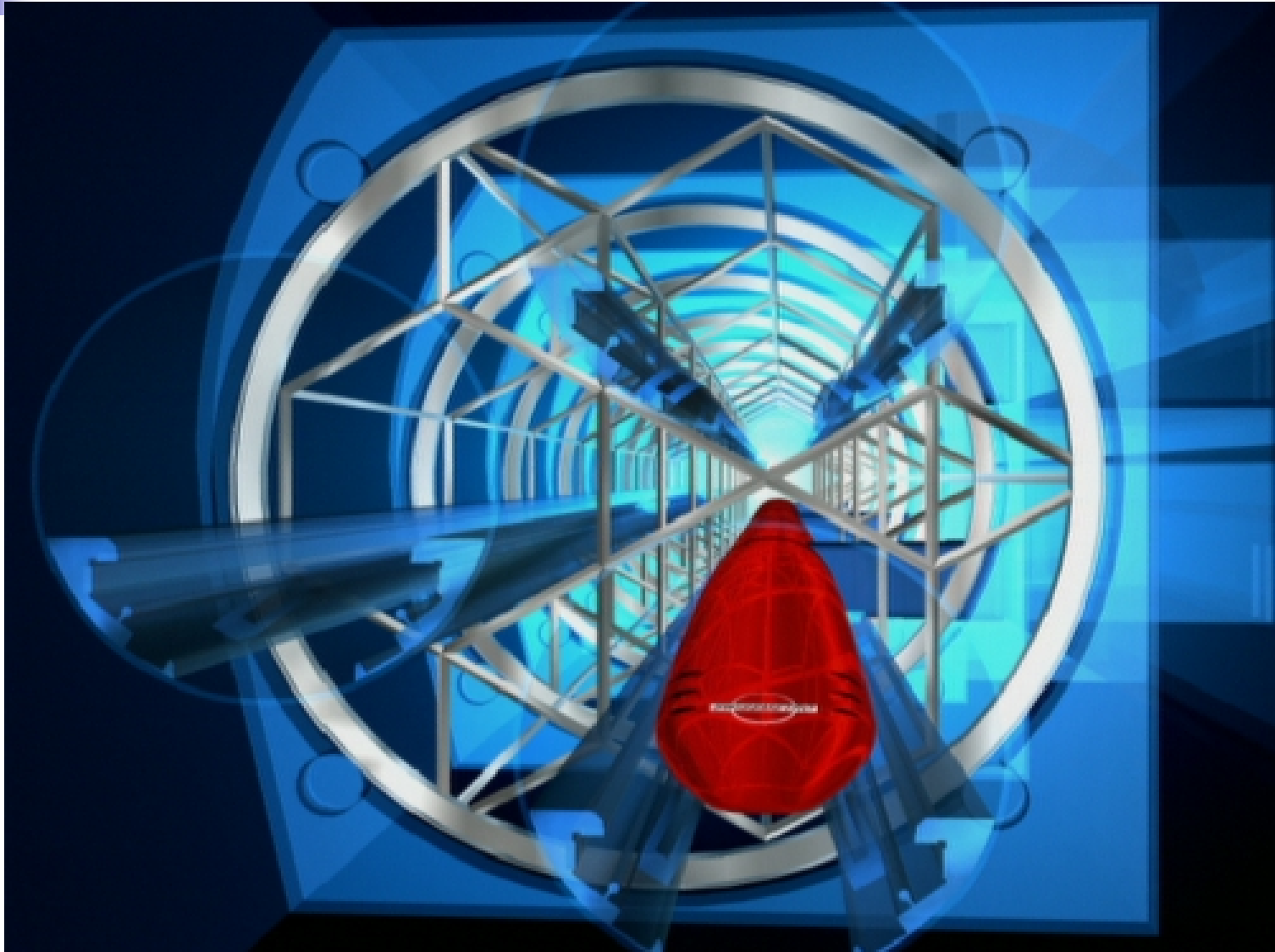

# Swissmetro Originale Technologien

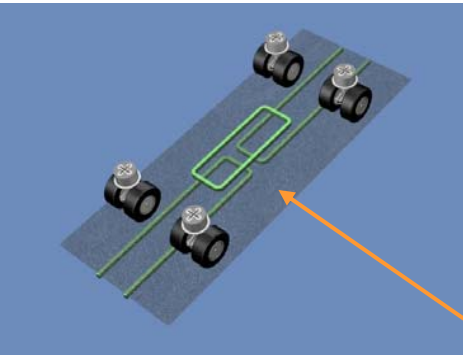

*Kontaktlos Energie Übertragung*

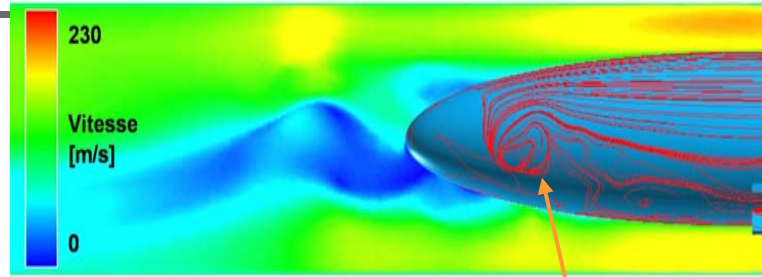

*Aerodynamik*

*Numerische  
Plattform*

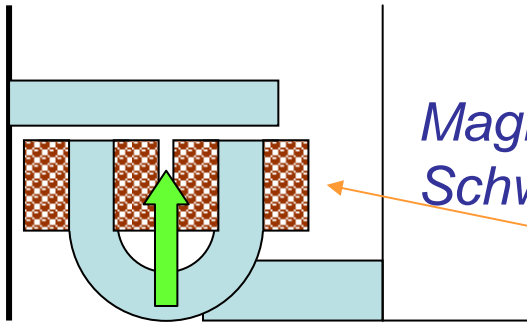
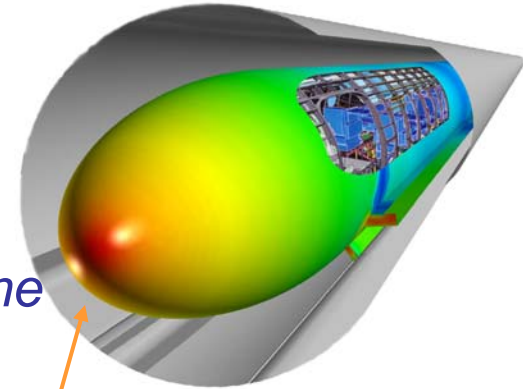

*Magnetische  
Schwebe Technik*

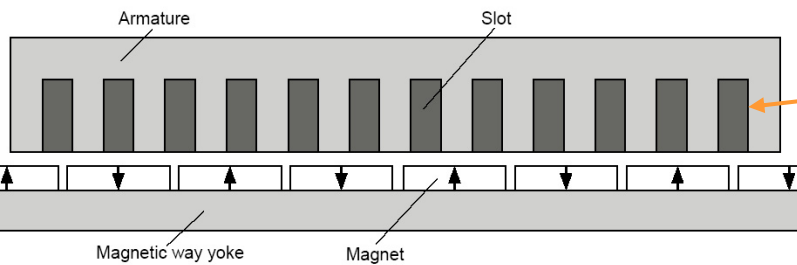

*Linearmotor*

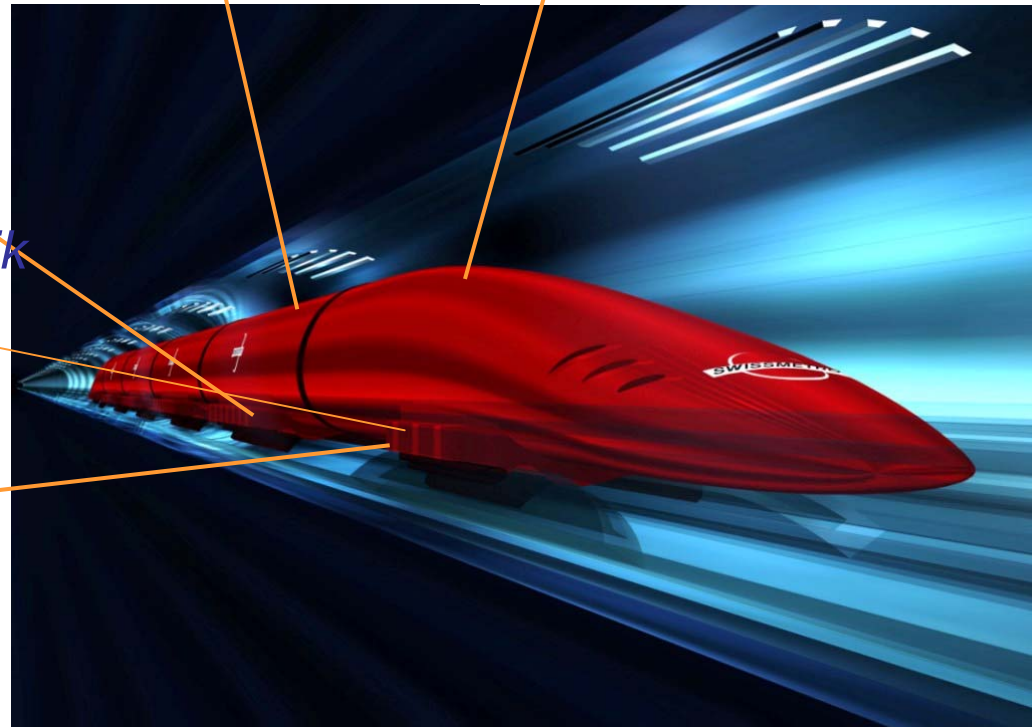



# U- Bahn

## Klassisch

Ø 5.8 m

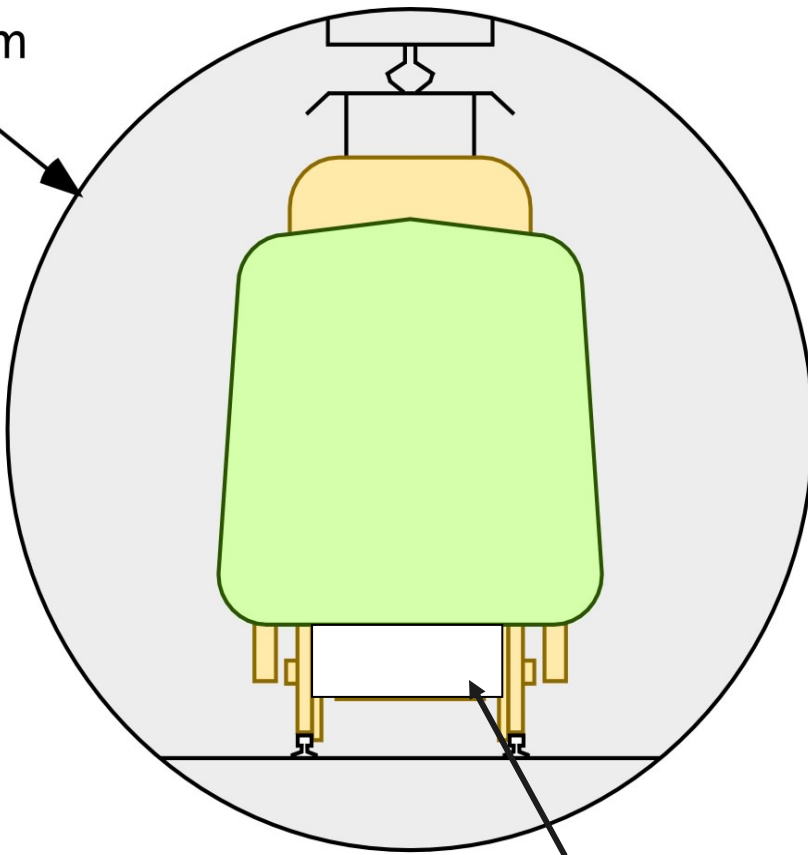

Drehmotor

## Linearmotor

Ø 4.0 - 4.3 m

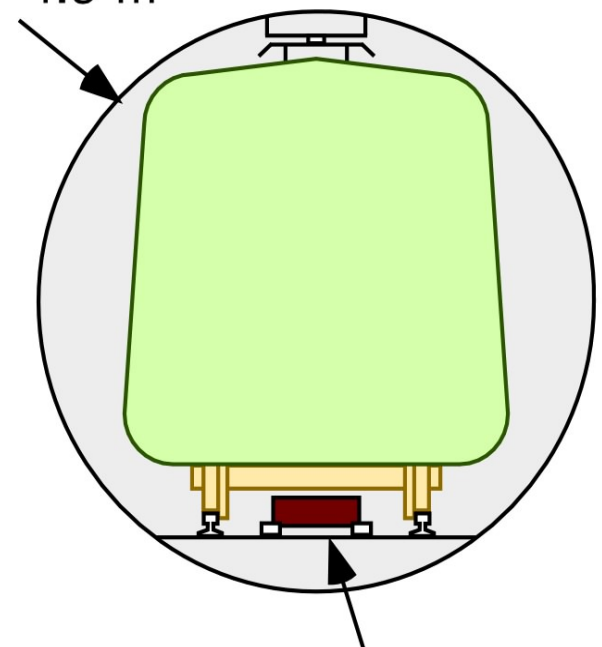

Linearmotor

# Induktion Linearmotor

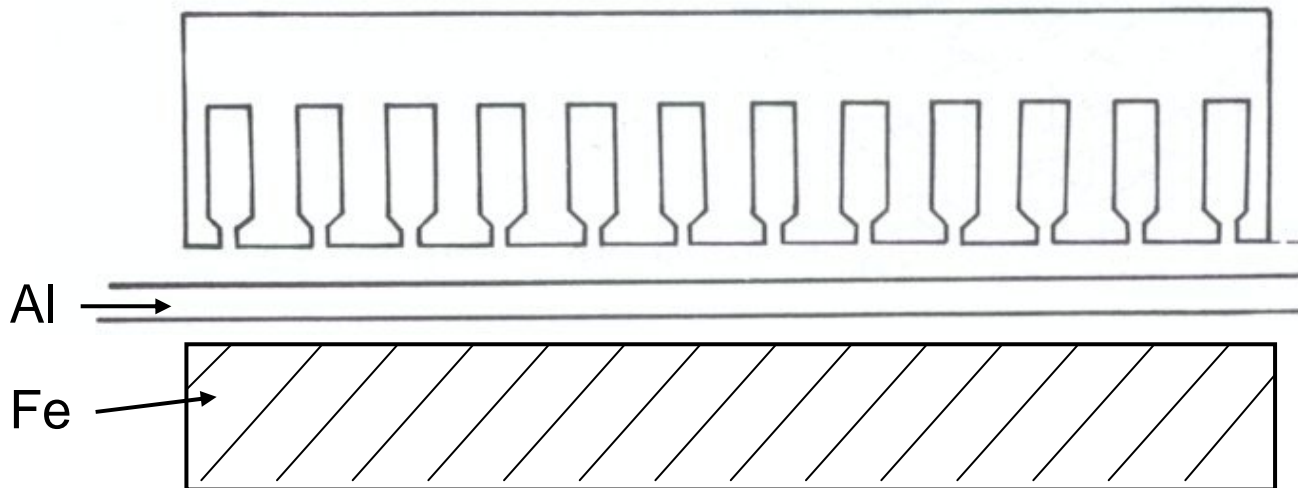
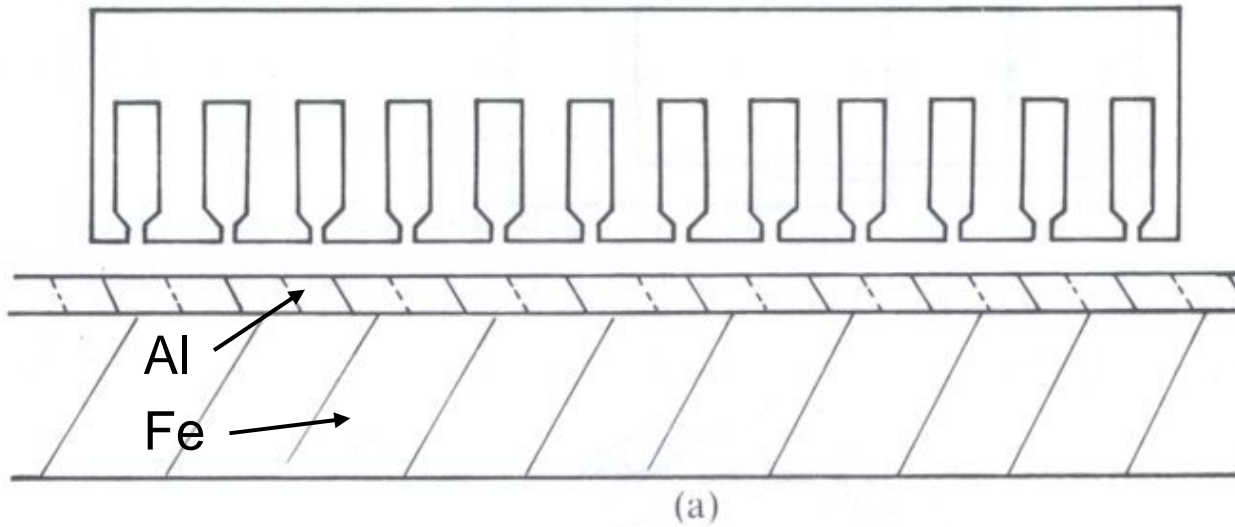

# Testanlage - EPFL

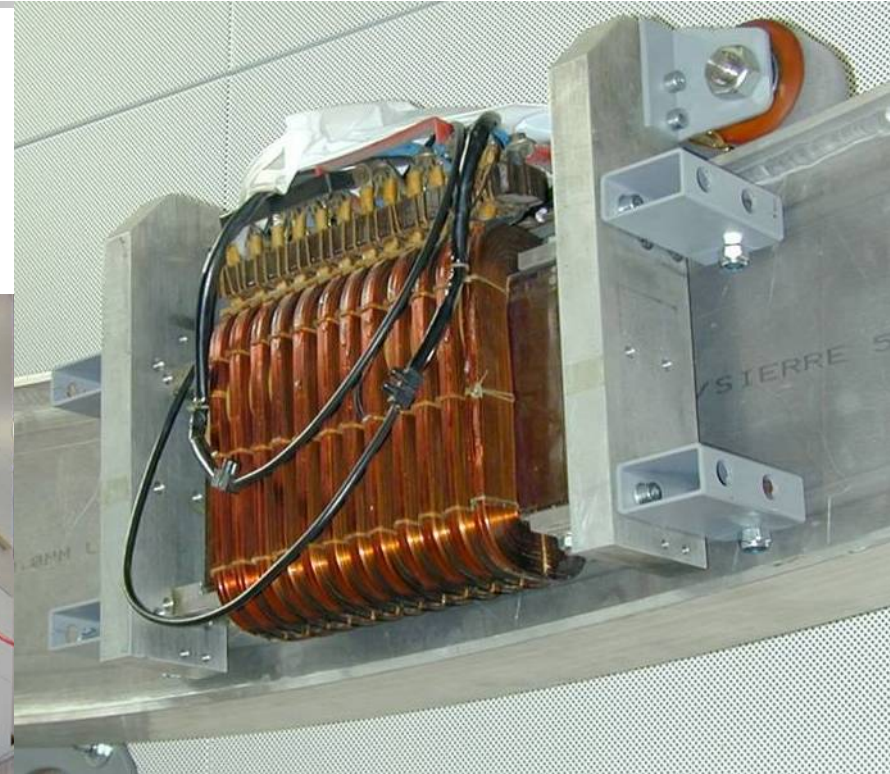

# Linearmotor

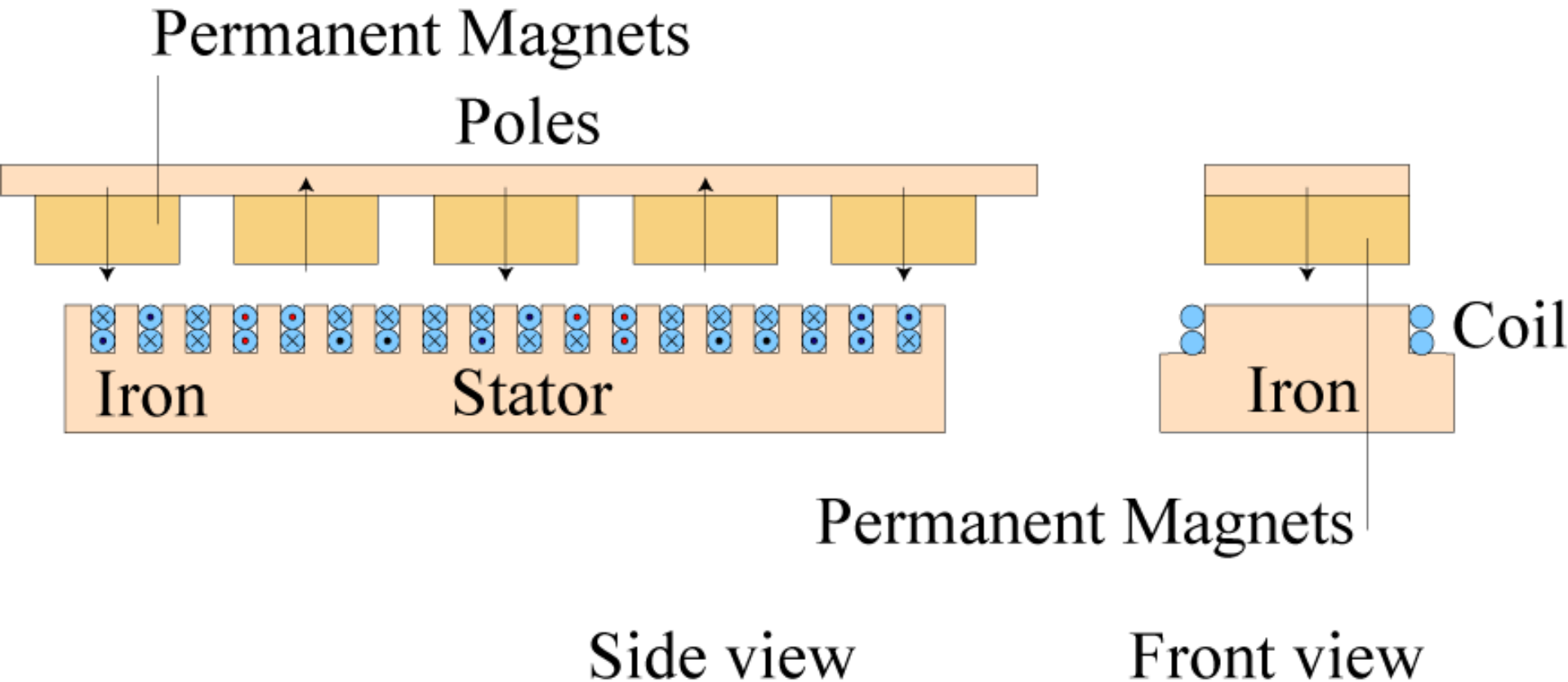

# Testanlage

*Drehsystem  
= Fahrzeug*

*Homopolar  
synchron-  
Linearmotor*

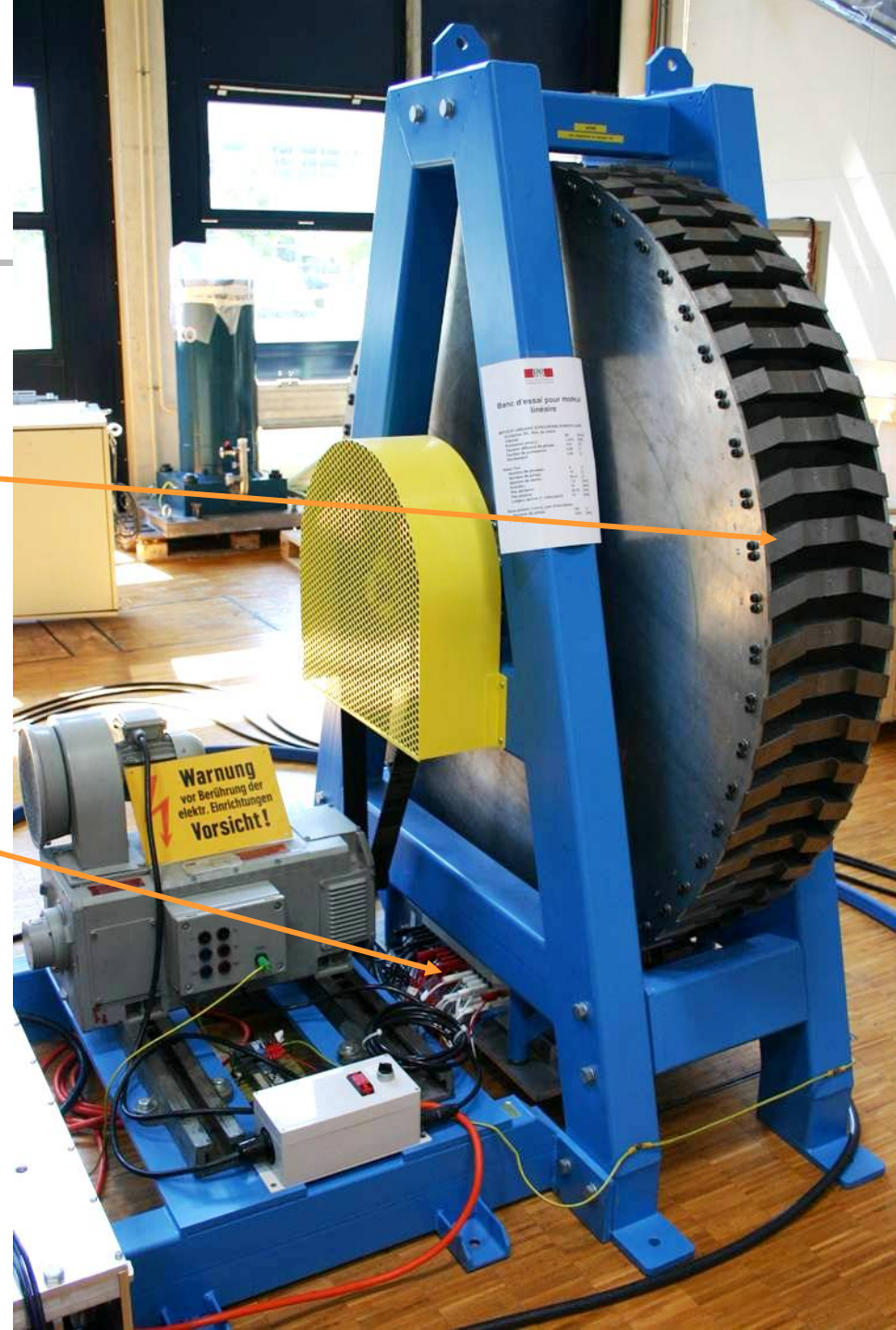

# Magnetische Schwebetechnik

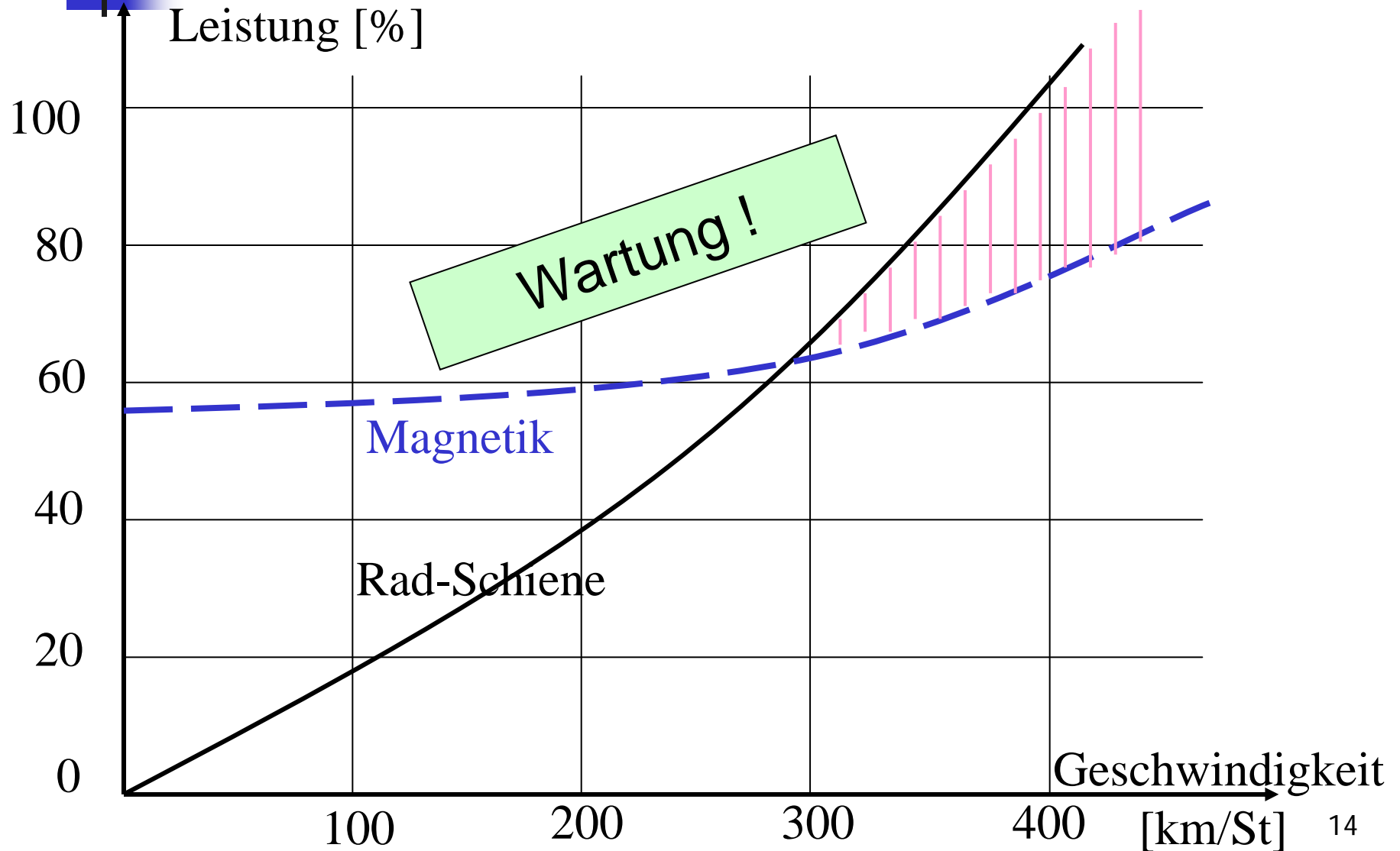

# Tunnel – Investitionskosten

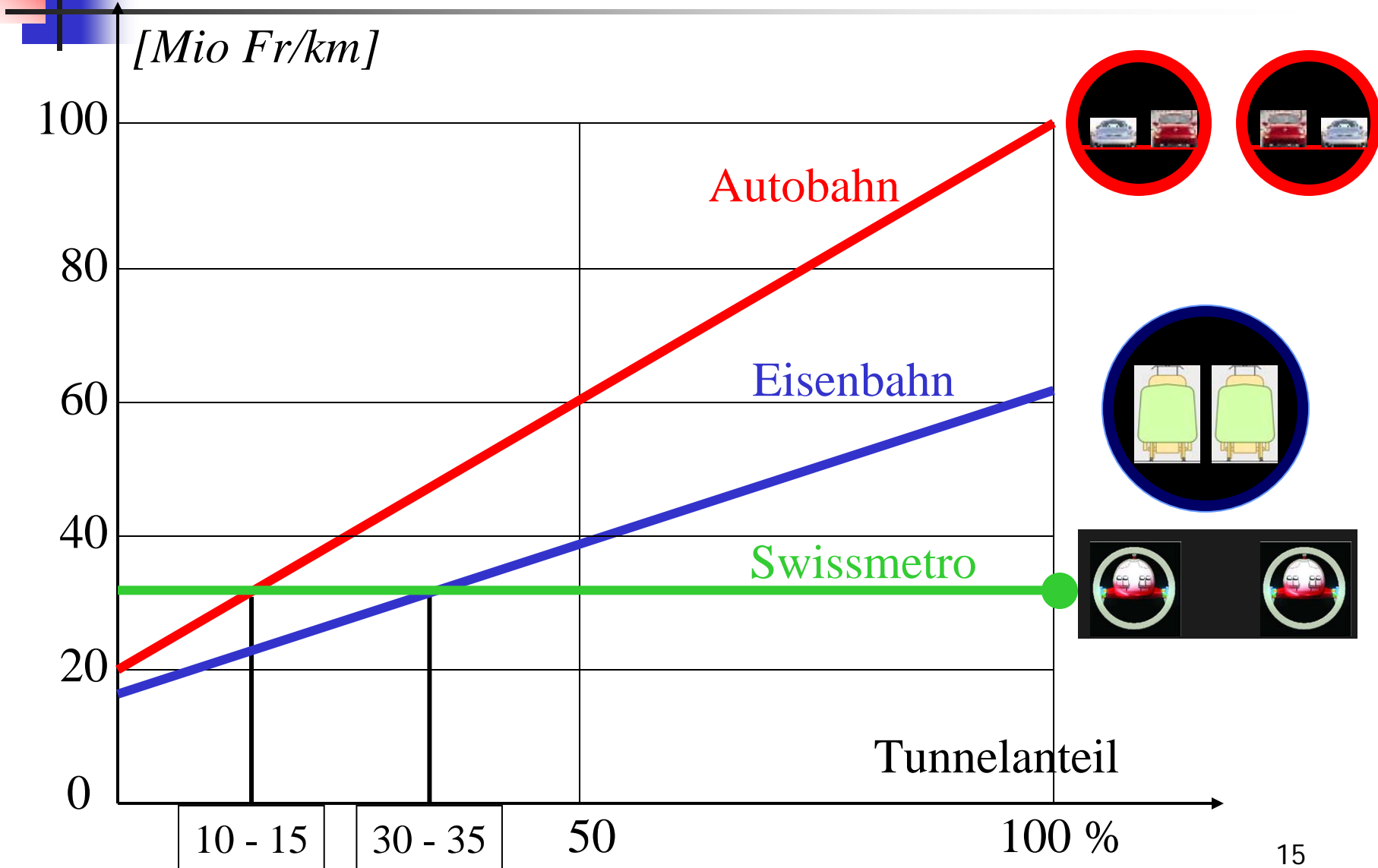

# Numerische Kraft



SGI Altix 350



# Aerodynamik

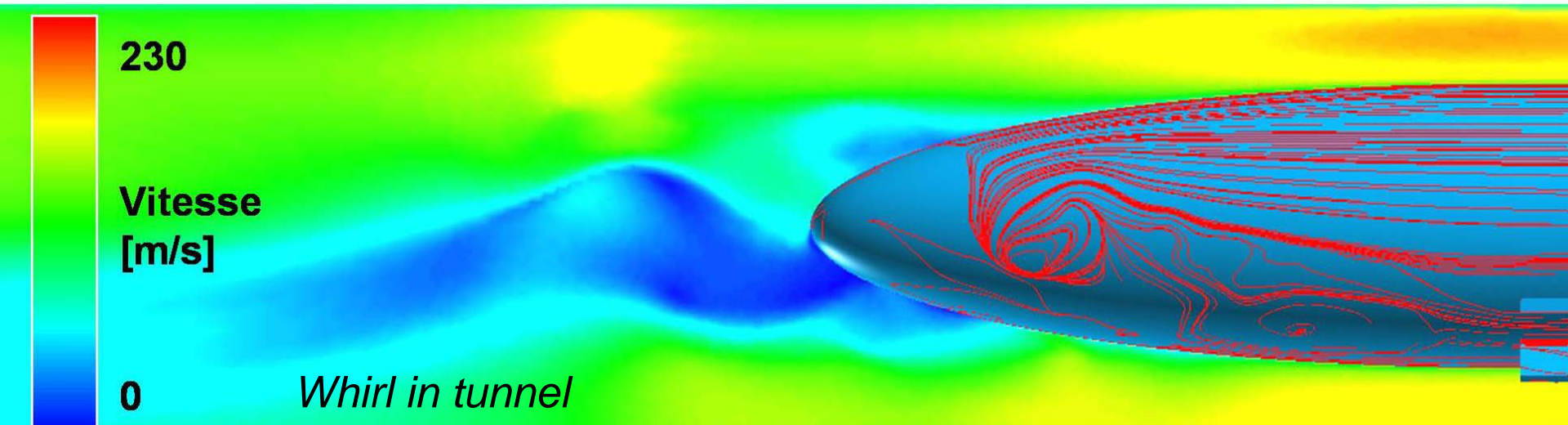
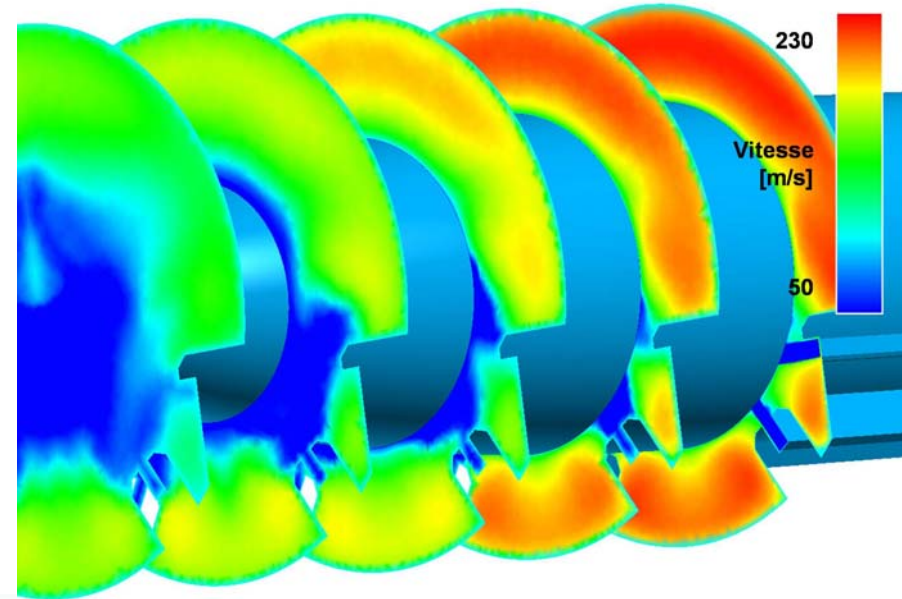
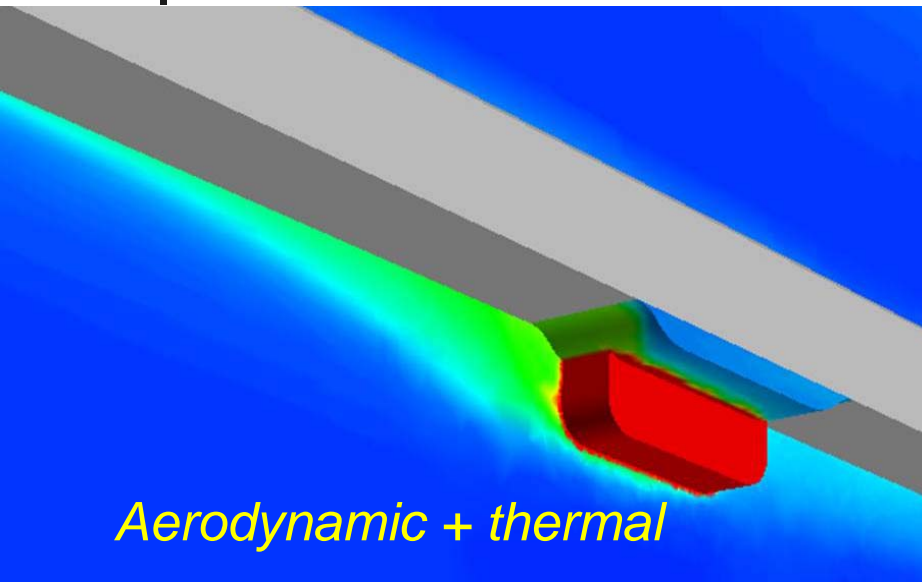

# Kontaktlos Energieübertragung

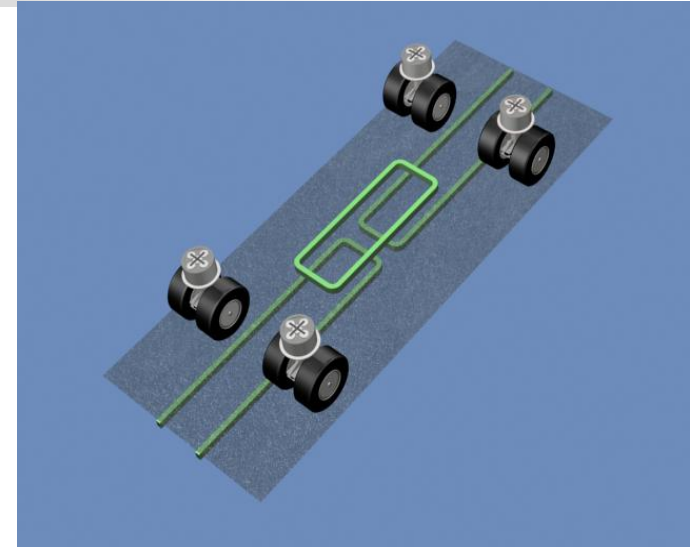
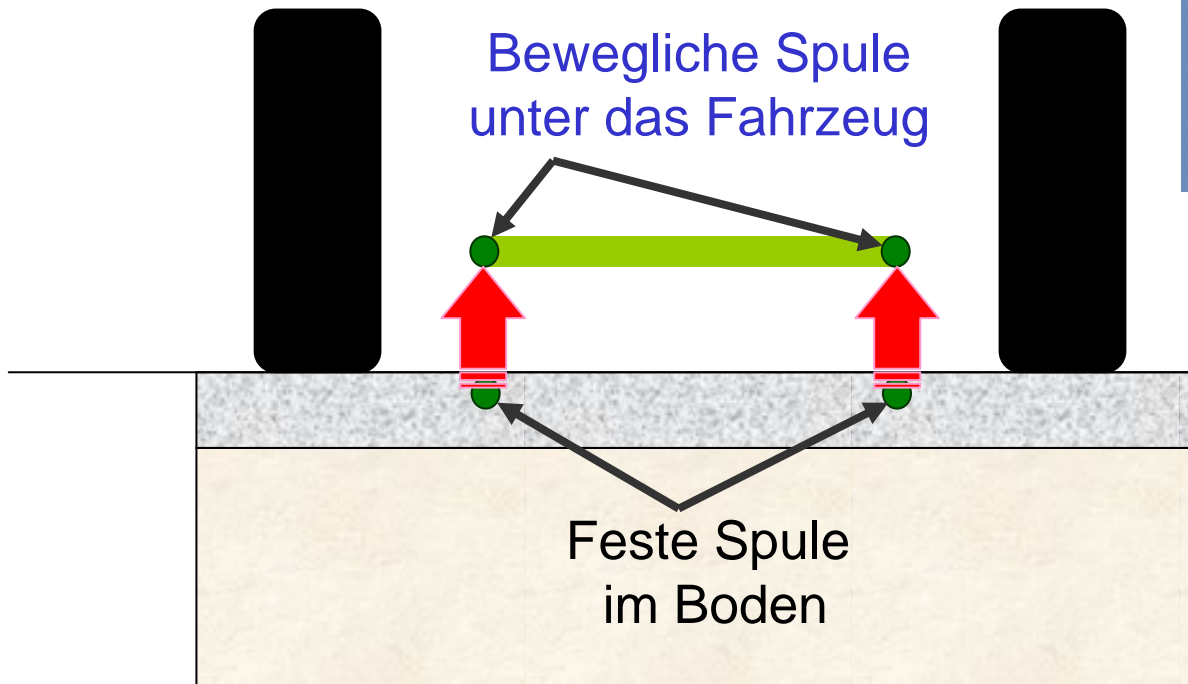

*Ertrag  
90 bis 95 %*

# AGV (Prototyp)



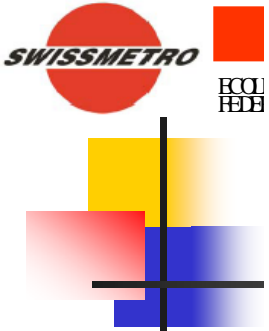

# APM

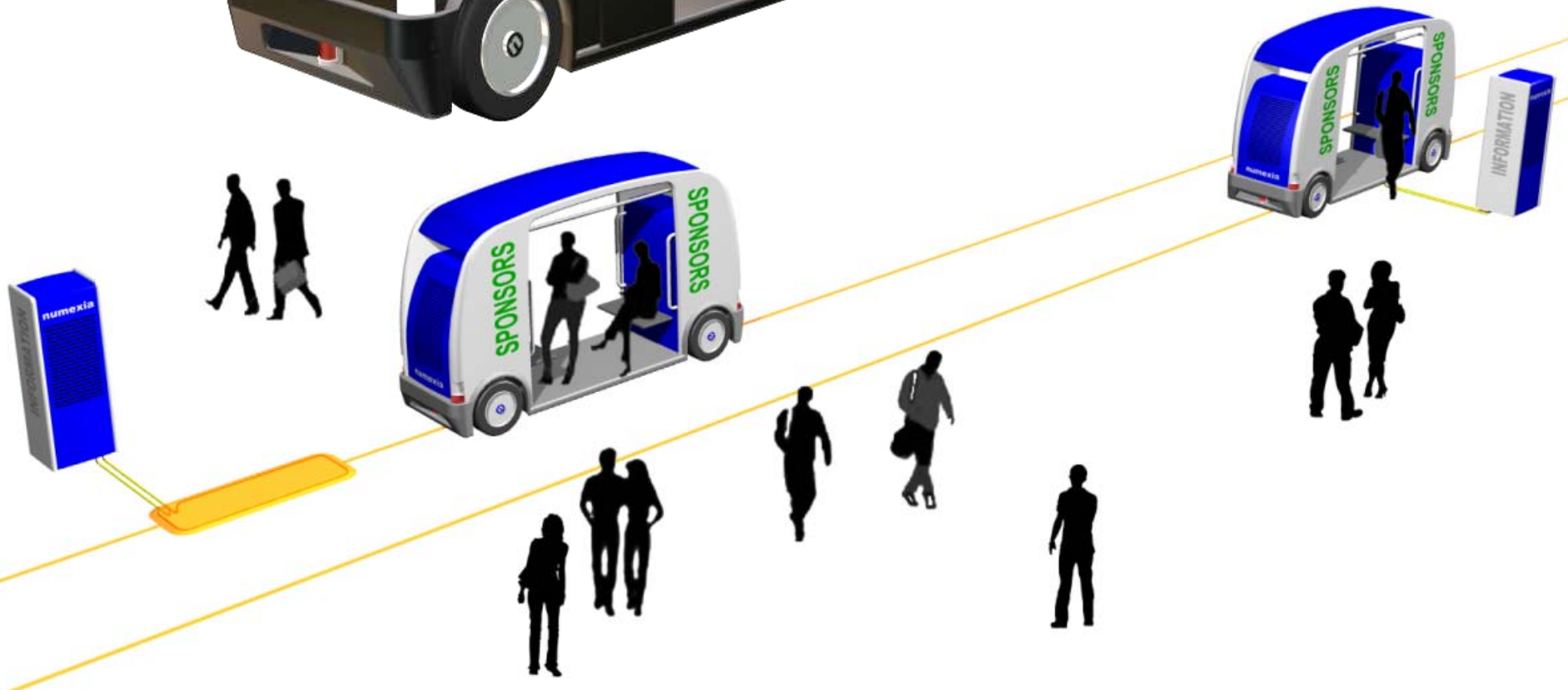

## Struktur

1. Fahrzeugzelle
2. Energiestation
3. Leistungselektronik
4. Energielagerung in Supercap
5. Sicherheitsystem
6. Antrieb durch Radmotoren
7. Energieübertragung
8. Infrastruktur

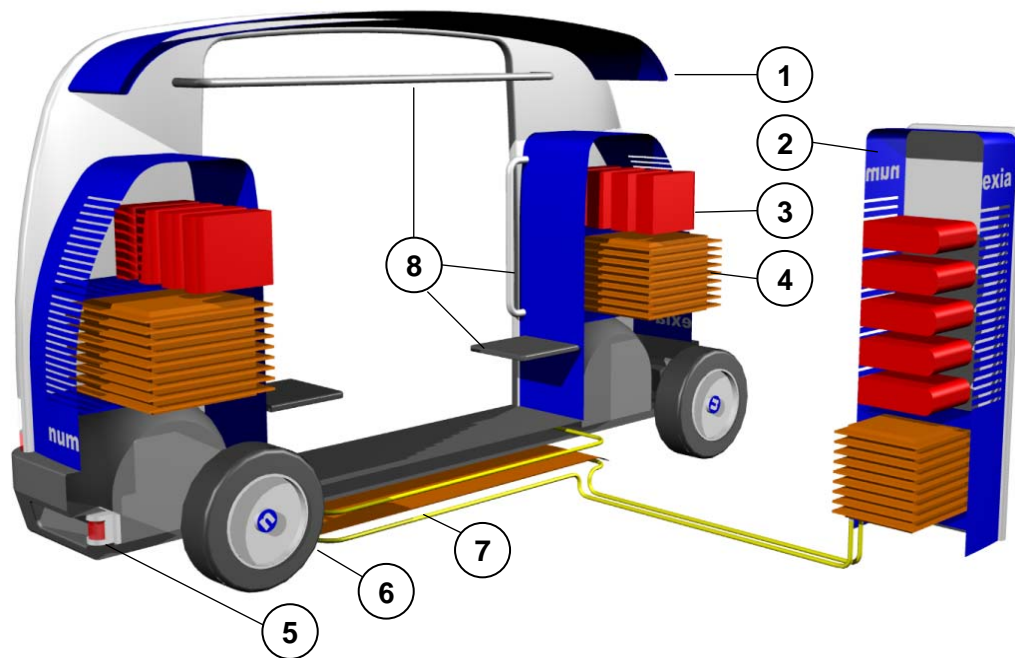

## Lärm an 300 km/St

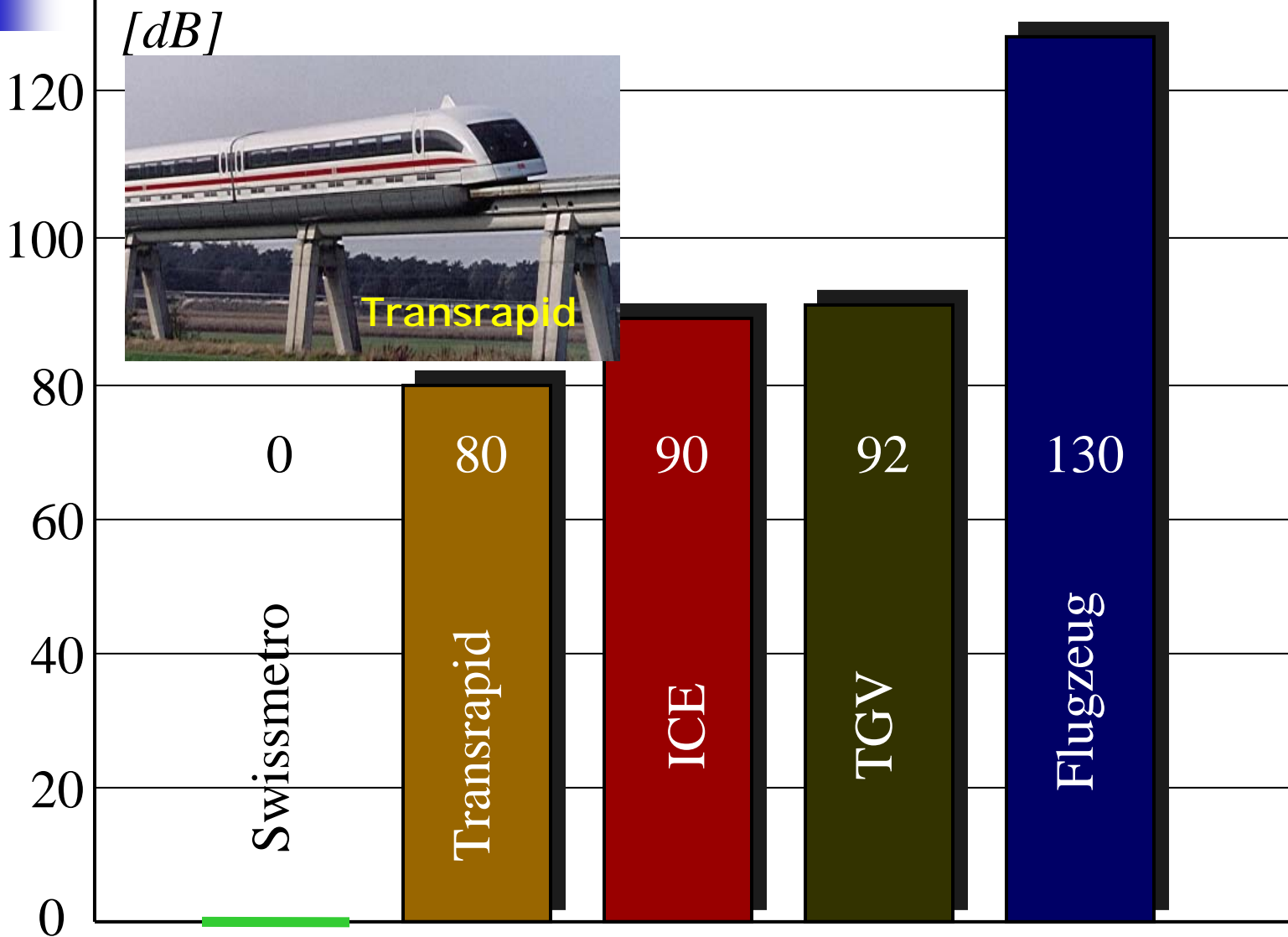

# Landbesetzung [m<sup>2</sup>/m]

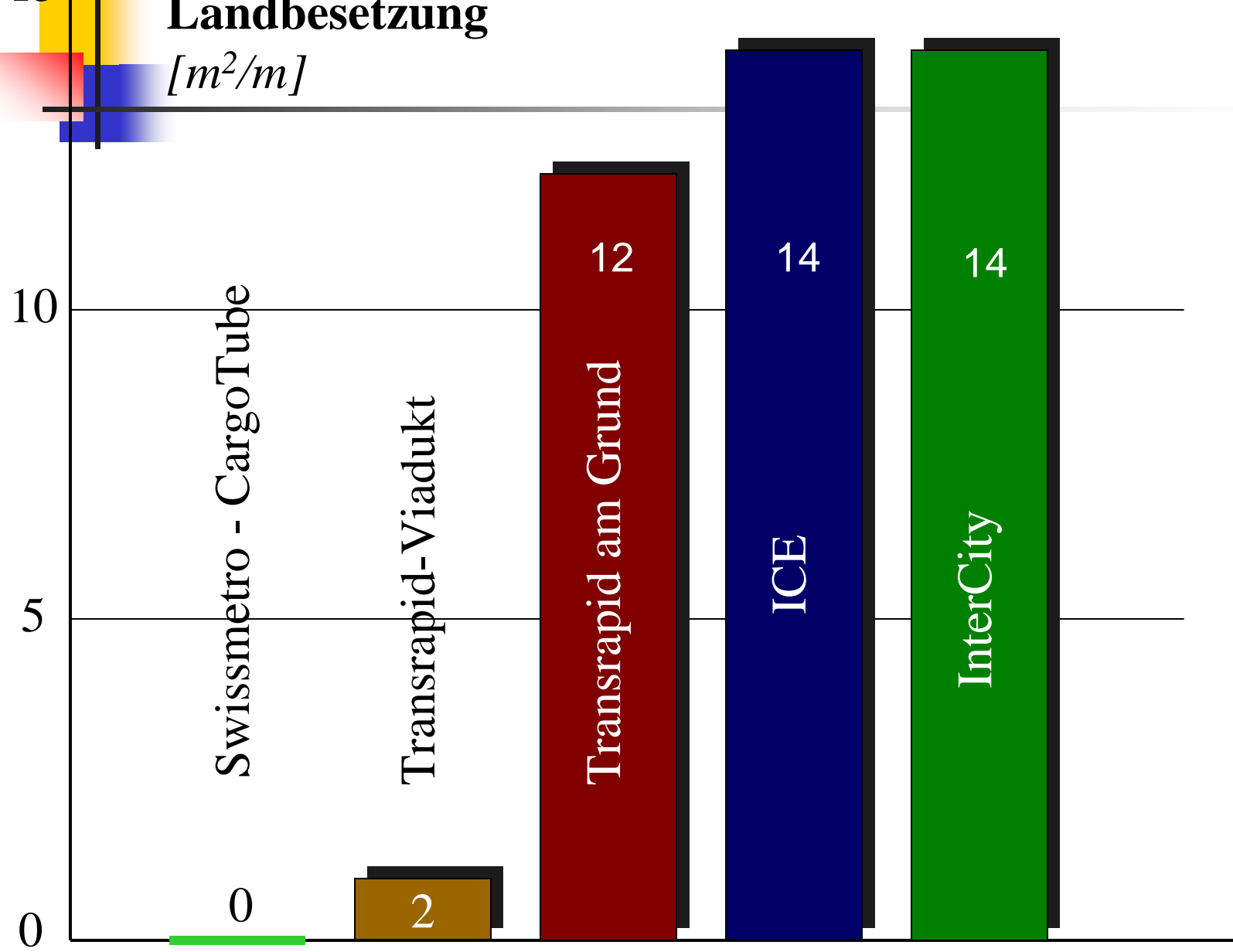

# Wartungskosten

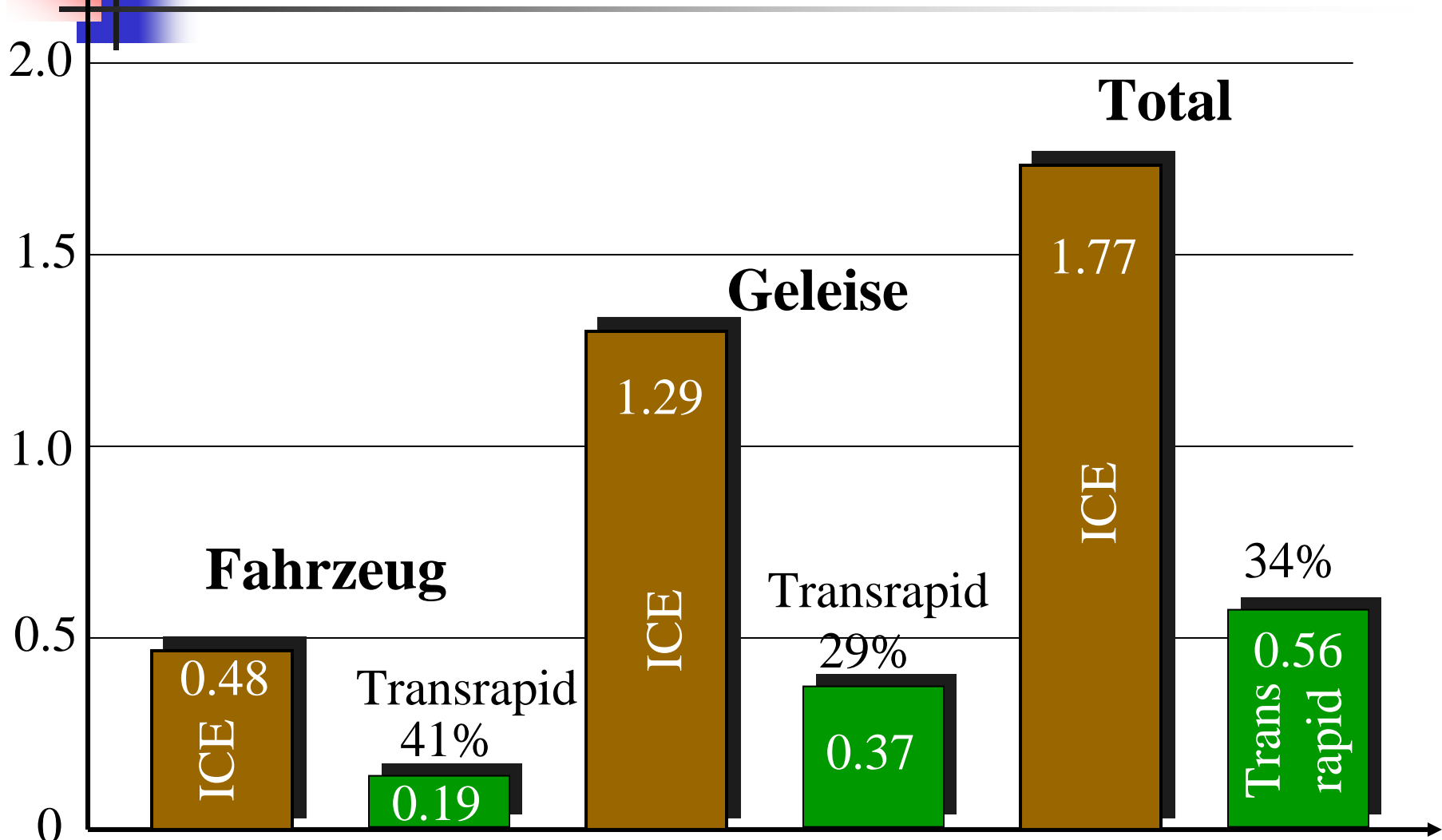



*Wählen...*

*Genève*

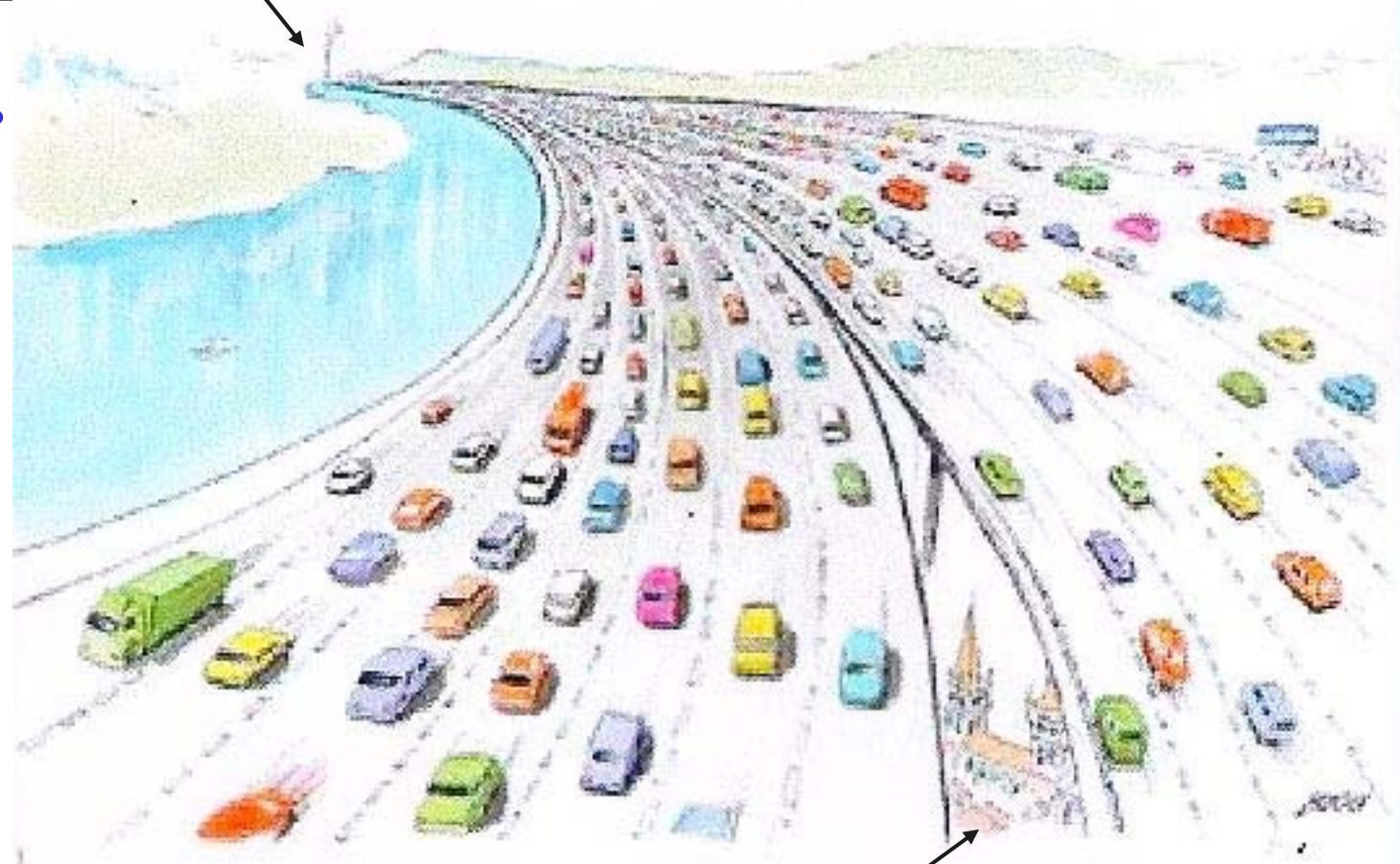

*Lausanne*

